

SICUREZZA 2.0

AGB EURO LOCK W/ DUO LATCH

Description

Embedded lock with patented co-moulded self-lubricating latch and bolt. Reversible spring latch.

AGB matched the best qualities of the two materials ensuring solidity and silence during the closing movement. The 4 lateral guides, in fact, drive the latch movement until it gets completely into the lock, ensuring fluidity, smoothness and noise reduction.

Application

For interior and main timber doors.

Mounting

Prepare cutout and mill the panel according to the dimensions shown in the diagram (pg.2) Secure the lock with two 4.5x25 mm screws. To reverse the spring latch, push it out of the forend by pushing with a screwdriver against the screw on the back, then rotate it.

 **Lock Type**
Euro Lock

 **Axis**
85mm

 **Backsets**
45mm
50mm
60mm

 **Material**
Stainless Steel
Steel
Nylon

 **Steel Forend**
Round End
22 x 238mm



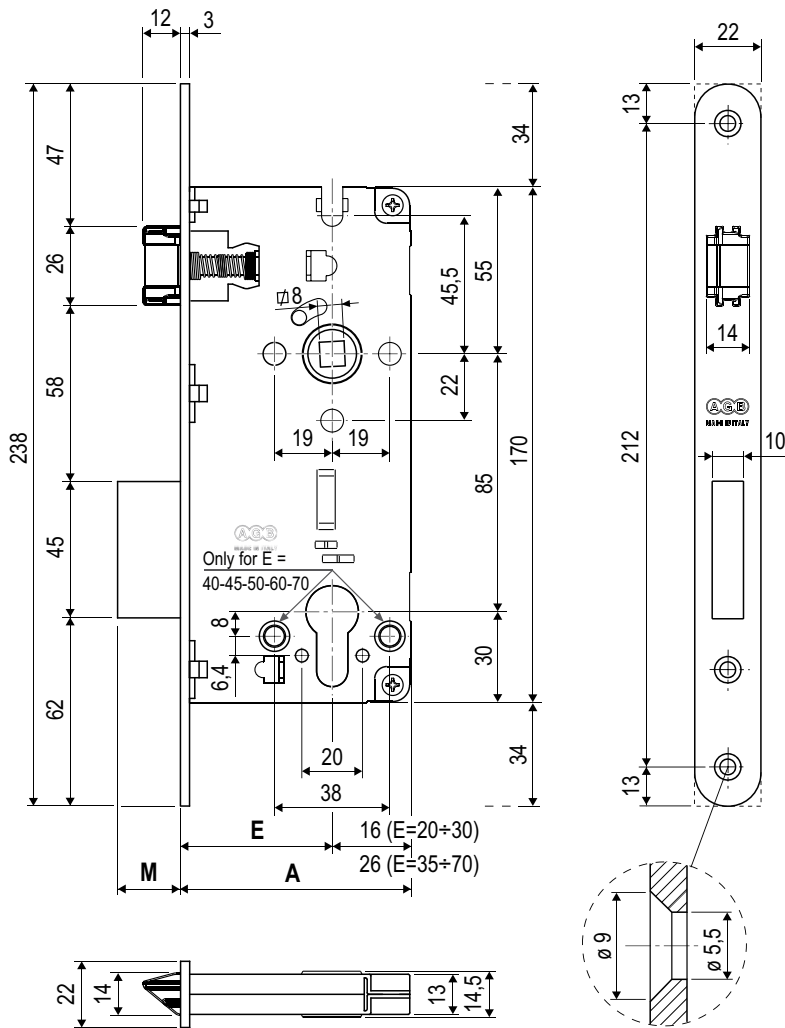

 **Hub**
8mm







E	A	M	No. of throws
20	36	12	1
25	41	12	1
30	46	12	1
35	61	21	2
40	66	21	2
45	71	21	2
50	76	21	2
60	86	21	2
70	96	21	2

FINISHES & CODES

Not all items are stocked in Australia

45mm Backset	60mm Backset		
 Nickel Plated B80851.45.06	 Nickel Plated B80851.50.06	 Matt Chrome B80851.50.34	 Matt Black B80851.50.93

50mm Backset		
 Enamelled Brass B80851.50.03	 Enamelled Bronze B80851.50.22	 Matt Black B80851.50.93
 Nickel Plated B80851.50.06	 Matt Chrome B80851.50.34	

SICUREZZA 2.0 STRIKER PLATE

Round End with Shaped lip

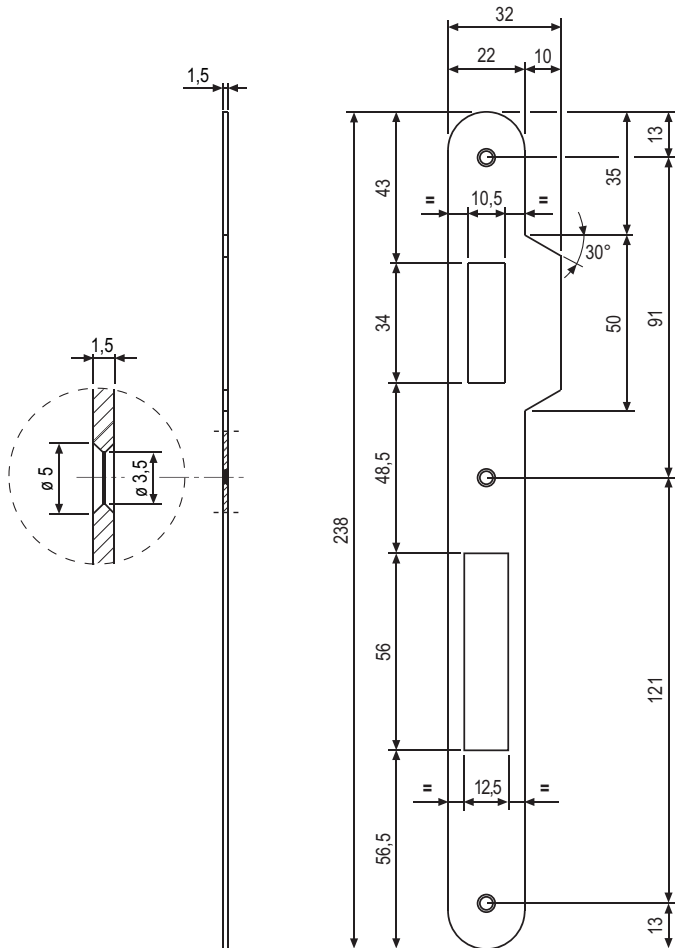

Description

Steel or brass striker with **round ends, 22mm wide, 238 mm long. 10 mm shaped lip for jamb protection** in area where spring latch strikers. Suitable for both right and left-handed applications.

Application

Used in combination with a Mortice lock with 22 mm forend, on interior and main flush doors with timber frame.

Mounting

Mill the frame according to the dimensions shown in the diagram. Install the striker with the lip flush with the edge of the frame. Fasten with three 3x25 mm screws.

7 Available Finishes



Enamelled
Brass

B00590.11.03



Nickel Plated

B00590.11.06



Matt Chrome

B00590.11.34



Matt Black

B00590.11.93



Enamelled
Bronze

B00590.11.22

Dust Box



Small | Black

B01060.21.93



Large | Black

B01060.22.93