

## 2 COMPONENTS

# ECLIPSE 3.2 HD SELF

High loading capacity self-closing hinges for heavy internal flush aluminum and wooden doors



Flush Doors with Rebate



Flush Doors without Rebate

The new concealed hinge with integrated closing system with spring Eclipse 3.2 HD Self is reversible with frame part reduced to 21 mm. Same millings of the Eclipse 3.2 range plus the milling for the spring body.

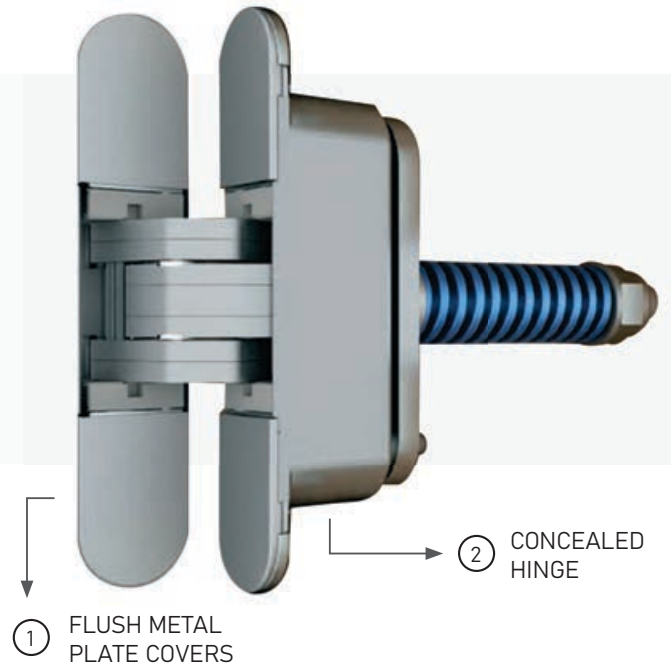

### 3 ADJUSTMENTS



In pressure  $\pm 1\text{mm}$   
Vertical  $\pm 2\text{mm}$   
Horizontal  $\pm 1.5\text{mm}$



**HEIGHT**  
115mm



**MAX. EXTENSION**  
14mm



### CAPACITY

According to the model of hinge where it is coupled with: Eclipse 3.2 or Eclipse 3.2 HD



### MILLING

The same millings of the Eclipse 3.2 hinges adding the spring milling



### MATERIAL

Steel



**OPENING**  
180°



**SELF-CLOSING SYSTEM**

### Finishes & Codes

#### 1. Concealed Hinges

**40kg Capacity**



**34** Matt Chrome Plated

**E39000.03.34**

**60kg Capacity**



**34** Matt Chrome Plated

**E39000.06.34**

#### 2. Flush Metal Plate Covers

**For 40kg and 60kg**



**34** Matt Chrome Plated

**E30200.16.34**

## Adjustments

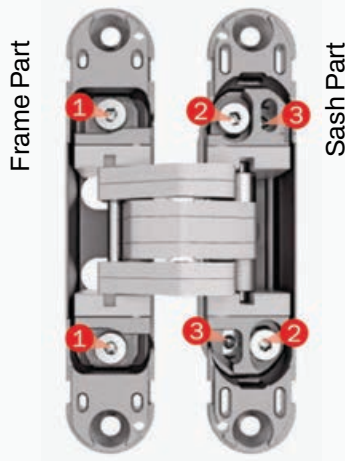

Three adjustments completely independent using a unique 3mm Allen Key.

- 1 In pressure  $\pm 1\text{mm}$**   
Loosen the screws and move the hinge body. After this operation fasten the screws.
- 2 Vertical  $\pm 2\text{mm}$**   
To reach the desired adjustment, loosen the screws and, against the spring thrust, move vertically the hinge body by using a screwdriver and the wedge. After this operation, fasten the screws.
- 3 Horizontal  $\pm 1.5\text{mm}$**   
Move the screws.

## Adjustment of Closing System

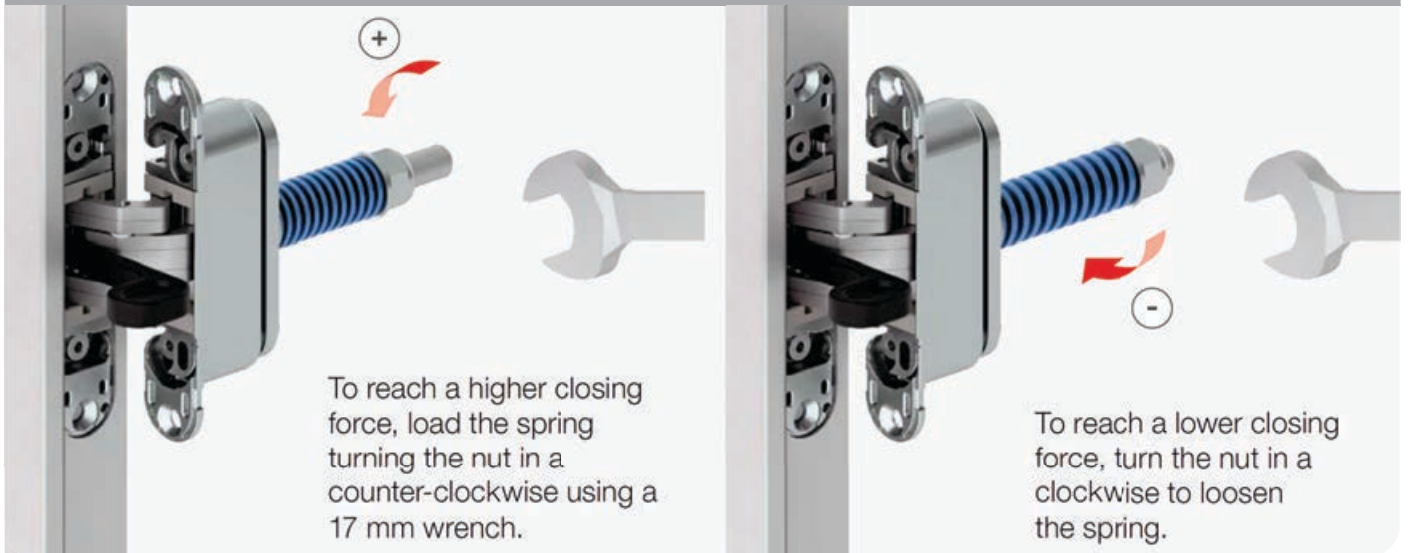

## Drilling Diagram

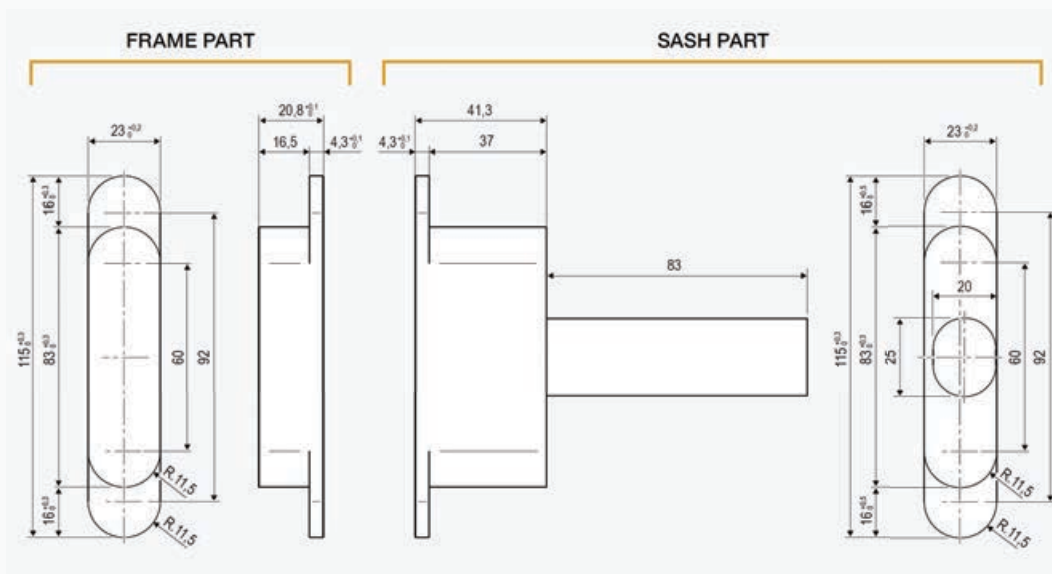



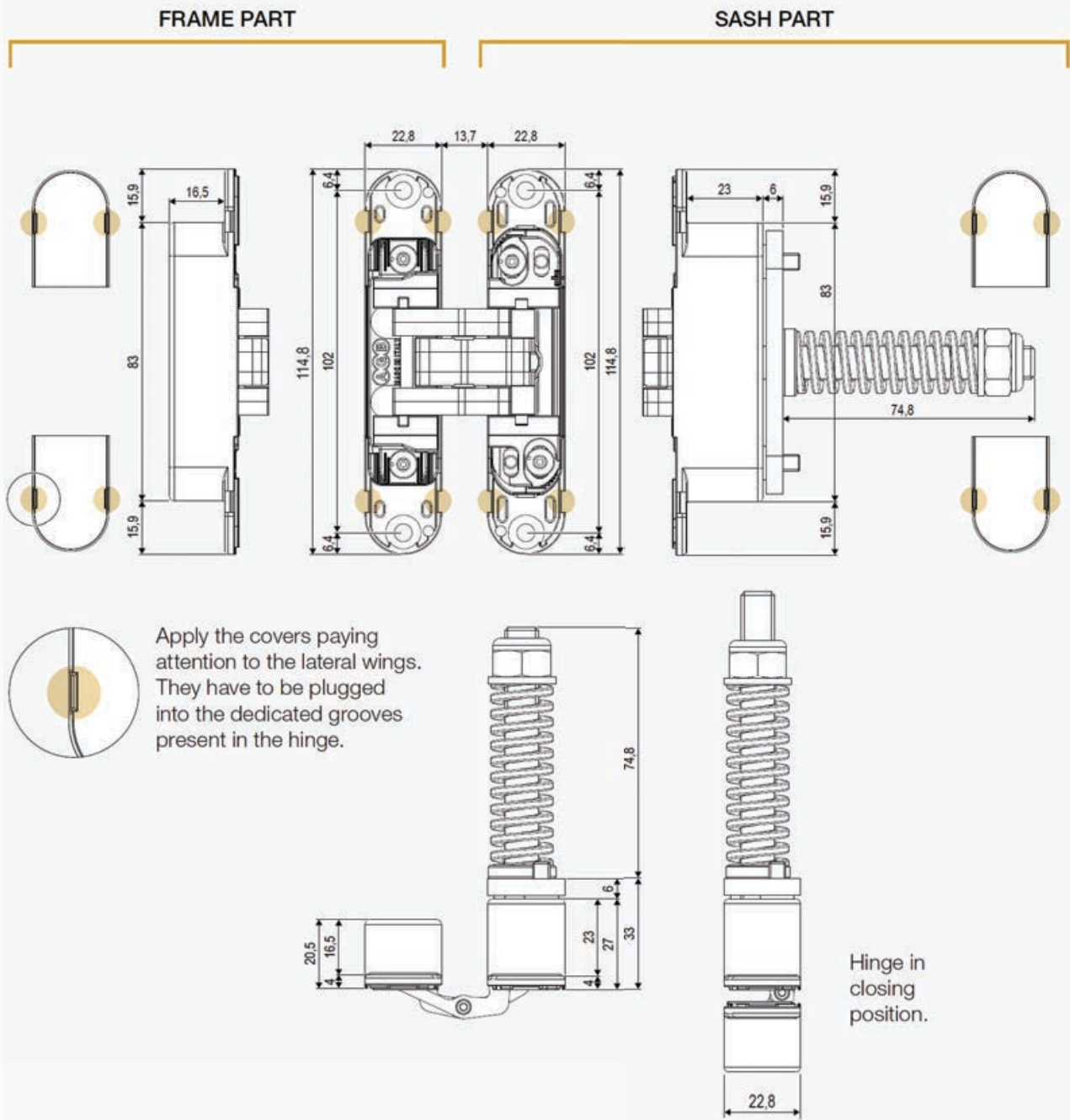

## Hinge Dimension

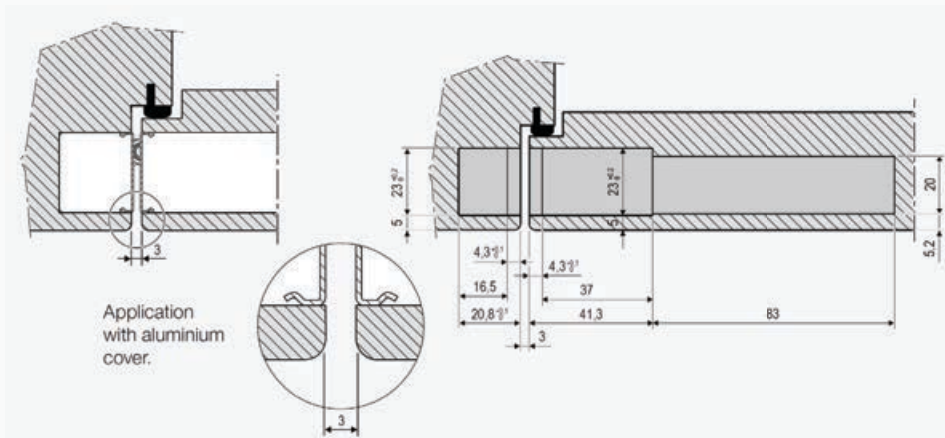

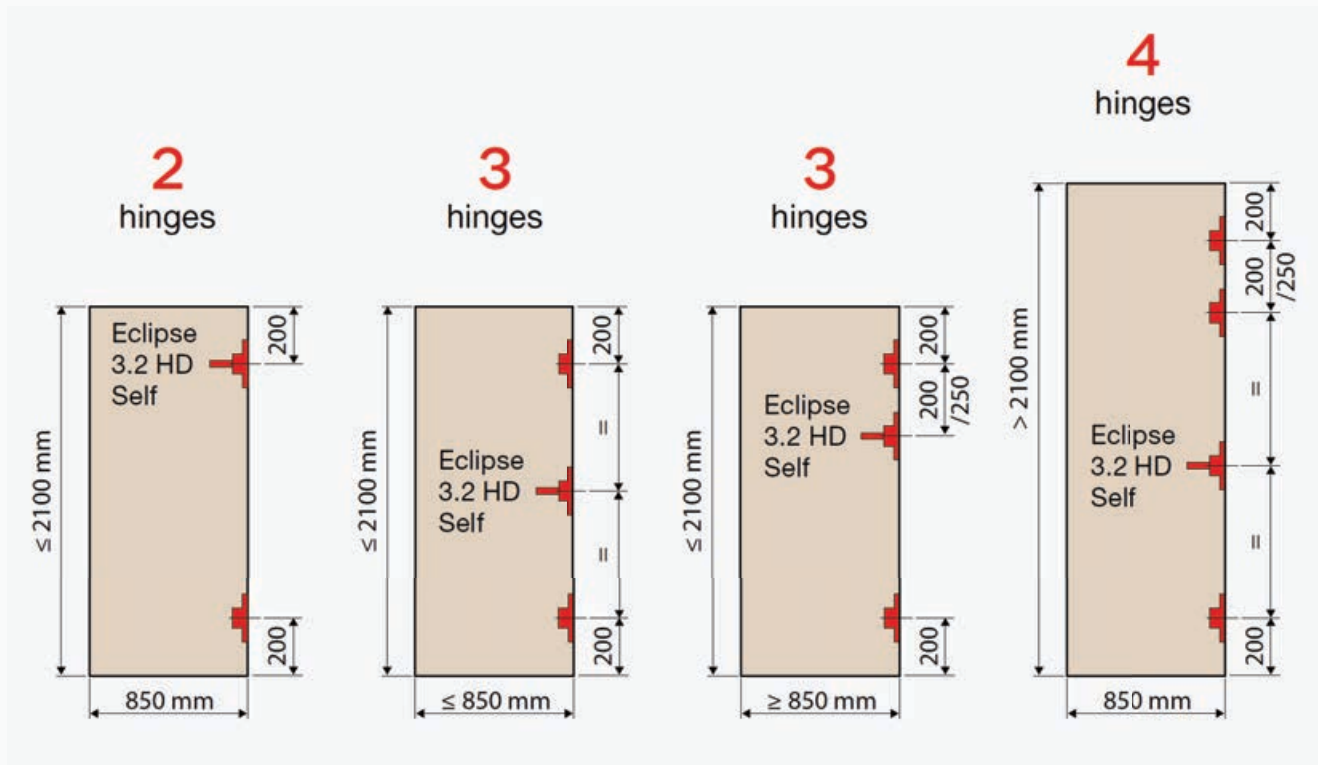
## Hinge Application





|  | TECHNICAL INFORMATION   |  |  |
|---|---|--|--|
|   | <br>Spring | <br>Suitable for sashes | <br>Compatibility |
| 3.2 HD Self   | Blue  | Up to 40 kg  | Eclipse 3.2<br>Eclipse 3.2 HD  |
|   | Red   | Up to 60 kg  | Eclipse 3.2<br>Eclipse 3.2 HD  |

**CAPACITY**

The capacity depends on the type of hinge with which it is combined. Refer to the “Hinge application fields” of the Eclipse 3.2 and Eclipse 3.2 HD series.