

PIVOTICA PRO 150

ARGENTA | Concealed Self-Closing Pivoting Hinges

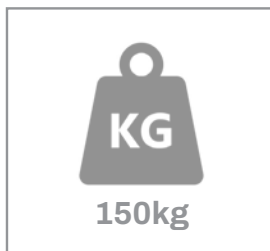

OVERVIEW



For interior doors weighing up to **150kg**

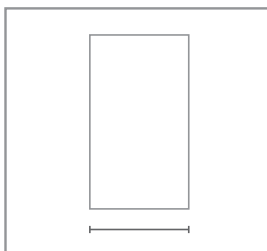

Max. Door Width **2000mm**
(Only in de-centralised position)

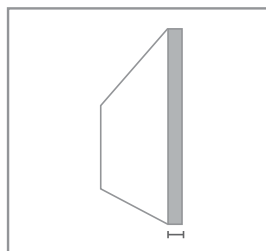

Min. Door Thickness **50mm (wood doors)**

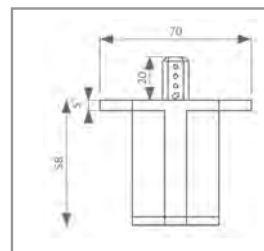

Light, small & compact.
Smallest head in the market

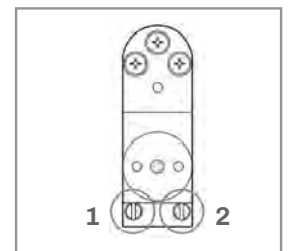

Adjustable closing speed & active speed dampening that allows **the door to always return to 0°**

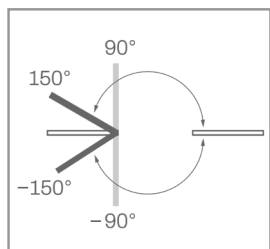

Opening **angle of 150°** in both directions or **hold open at 90° to keep door open.**

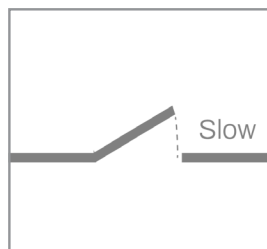

Soft close from pivot's **hydraulics system** for wall protection and prevent finger jamming.

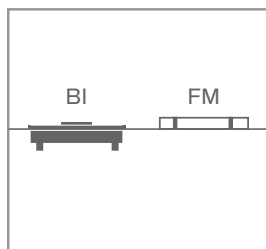

Floor Mounted (FM) or **Built-In (BI)** options for the foot plate.



Choose from 3 pivot points: **corner, de-central and central position.**

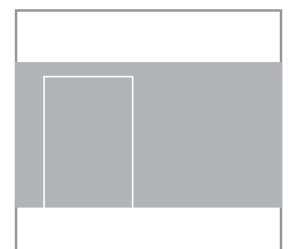

Pivot keeps the door perfectly flush with the wall, ensuring there are no interruptions to the sleek design of the wall.

ORDER CODES

FM F90 91500028
FM F0 91500031

BI F90 91500036
BI F0 91500035

FM Floor Mounted
BI Built-In

F0 0° / Free Swing
F90 90° / Hold Open

OVERVIEW

The universally applicable, compact and virtually invisible pivot door hinge Argenta® Pivotica® Pro 150 is the ideal solution for standard interior pivoted doors. The Argenta® Pivotica® Pro 150 is **suitable for modern residential homes as well as public buildings and offices.**

Pivot Points

Pivot hinge can be embedded in the lower corner of the doors, but also at a decentralized or centered position. Depending on the selected option, the door width will vary.

Corner of door:

Maximum door width is **1065mm.***
The **minimum pivot point is:**
150kg: 60.5 mm

Central Position:

The maximum distance measured from the axis point to the lock side, and the maximum distance measured from the axis point to the hinge side, is equal and with a max of 1000mm

Recommended Pivot Point (mm)	Door Width (mm)	Max Axis Point From Lock Side
60.5	1000*	1000*
100	1100	1000
200	1200	1000
300	1300	1000
1000	2000	1000

Applies for both floor-mounted & Built-In

Decentralized position:

The maximum distance measured from the axis point to the lock side of the door is **1000mm**; the remaining distance, measured from the axis point to the hinge side, is always smaller.

EXCEPTION

***When the pivotica® Pro is embed on the corner of the door, and the door weight is max. 100 kg, a door width up to max. 1250 mm can be applied. This exception is not applicable in a decentralized of central position.**

Adjustable Closing Speed

The closing force of the pivot hinge is adjustable according to door weight and width by means of a built-in hydraulic spring.

The closing force can be adjusted on two levels:

1. Closing Speed
2. Soft-Close

By adjusting the door, it will return to neutral perfectly after only a few swings

FIXED POSITION / HOLD OPEN

Hold open F90 variation is equipped with 3 fixed positions, namely -90°, 0°, 90° while the free swing F0 has a max. opening angle of 150°

Easy & Quick Installation

Thanks to its compact dimensions, the special wrench provided and the pivoting system in the door, a door with the pivot hinge is simple and quick to install and uninstall. Finally, there is no need for a floor pot, making the installation even faster and easier.

Adjustable Floor Plate

The floor plate is + 3mm and - 3mm adjustable in width and depth and can be further adjusted by 4°. As a result, the door will always return perfectly to neutral.

Compact, Small and Light-weight Head & Foot



Pivot Head

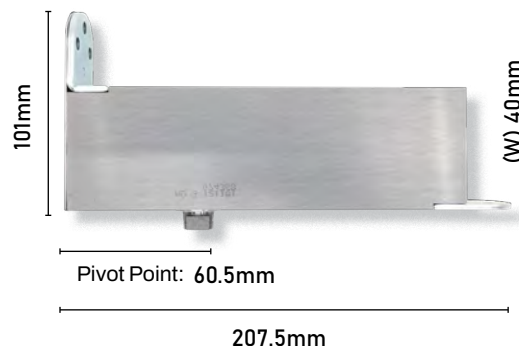

Pivot Body



Foot Plate



Satin Stainless Steel Cover Plate

Black Cover Plate

White Cover Plate

Floor Mounted

PIVOTICA PRO 150

Min - Max. Door Weight:	40 - 150 kg
Min - Max. Door Thickness:	50 - 100 mm
Door Width: ¹	<100kg = 2500mm >100kg = 2000mm
Min - Max. Door Height:	600 - 3000 mm
Width Adjustment:	-3 / +3 mm
Depth Adjustment:	-3 / +3 mm
Alignment:	-4 / +4 mm °
Holding Position: ²	0 ° or -90 ° / 0 °/90 °
Bottom Door Clearance:	13mm

(1) In the corner position, 2000 mm. Doors wider than 2000 mm need pivot to be placed in the de-centralised position using the bracket included.

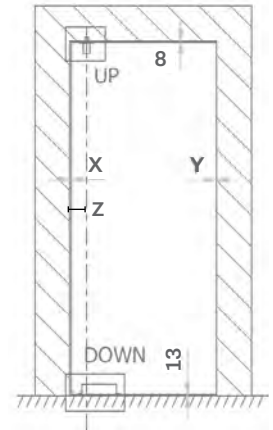

Door	X	Y	Z
50mm	7mm	3mm	68.5mm
54mm	8mm	3mm	69.5mm
60mm	9mm	3mm	70.5mm
64mm	10mm	3mm	71.5mm
70mm	12mm	3mm	73.5mm

(2) F0 = 0 ° / Free Swing at max.angle 150°
F90 = Fixed / hold open at 90°



Satin Stainless Steel Cover Plate

Built-In

PIVOTICA PRO 150

Min - Max. Door Weight:	40 - 150 kg
Min - Max. Door Thickness:	50 - 100 mm
Door Width: ¹	<100kg = 2500mm >100kg = 2000mm
Min - Max. Door Height:	600 - 3000 mm
Width Adjustment:	-3 / +3 mm
Depth Adjustment:	-3 / +3 mm
Height Adjustment:	+6 mm
Alignment:	-4 / +4 mm °
Holding Position: ²	0 ° or -90 ° / 0 °/90 °
Bottom Door Clearance:	Min.5 - Max. 11mm

Applies for both floor-mounted & Built-In

(1) In the corner position, 2000 mm. Doors wider than 2000 mm need pivot to be placed in the de-centralised position using the bracket included.

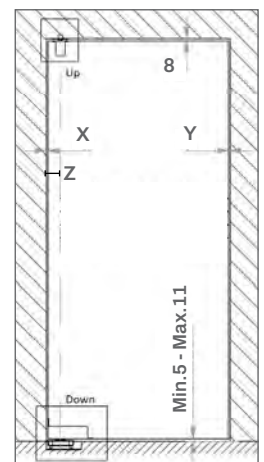

Door	X	Y	Z
50mm	7mm	3mm	68.5mm
54mm	8mm	3mm	69.5mm
60mm	9mm	3mm	70.5mm
64mm	10mm	3mm	71.5mm
70mm	12mm	3mm	73.5mm

(2) F0 = 0 ° / Free Swing at max.angle 150°
F90 = Fixed / hold open at 90°

MATERIALS & FINISH

Ceiling Plate	Stainless Steel	Bottom Pivot System		Top Pivot System	
Finish	Brushed Stainless Steel	Casing	Zinc Alloy	Casing	Zinc Alloy
			Finish: Adonised		Finish: Galvanised
Floor Plate	Stainless Steel	Spring	Stainless Steel	Spring	Stainless Steel
Finish	Brushed Stainless Steel	Control Components	Stainless Steel	Control Components	Stainless Steel

FOOT PLATE ADJUSTMENT

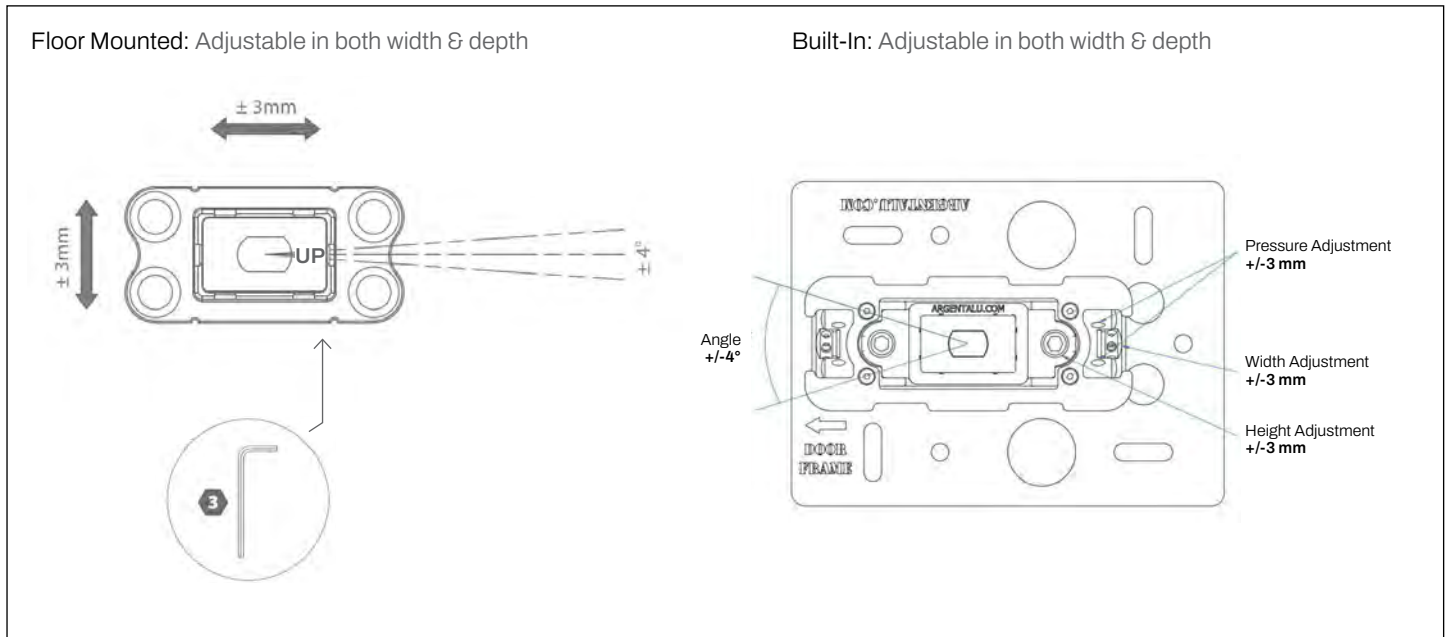

OPEN POSITIONS & SPEED ADJUSTMENT

* F0 = 0° / Free Swing
F90 = Fixed / Hold Open at 90°

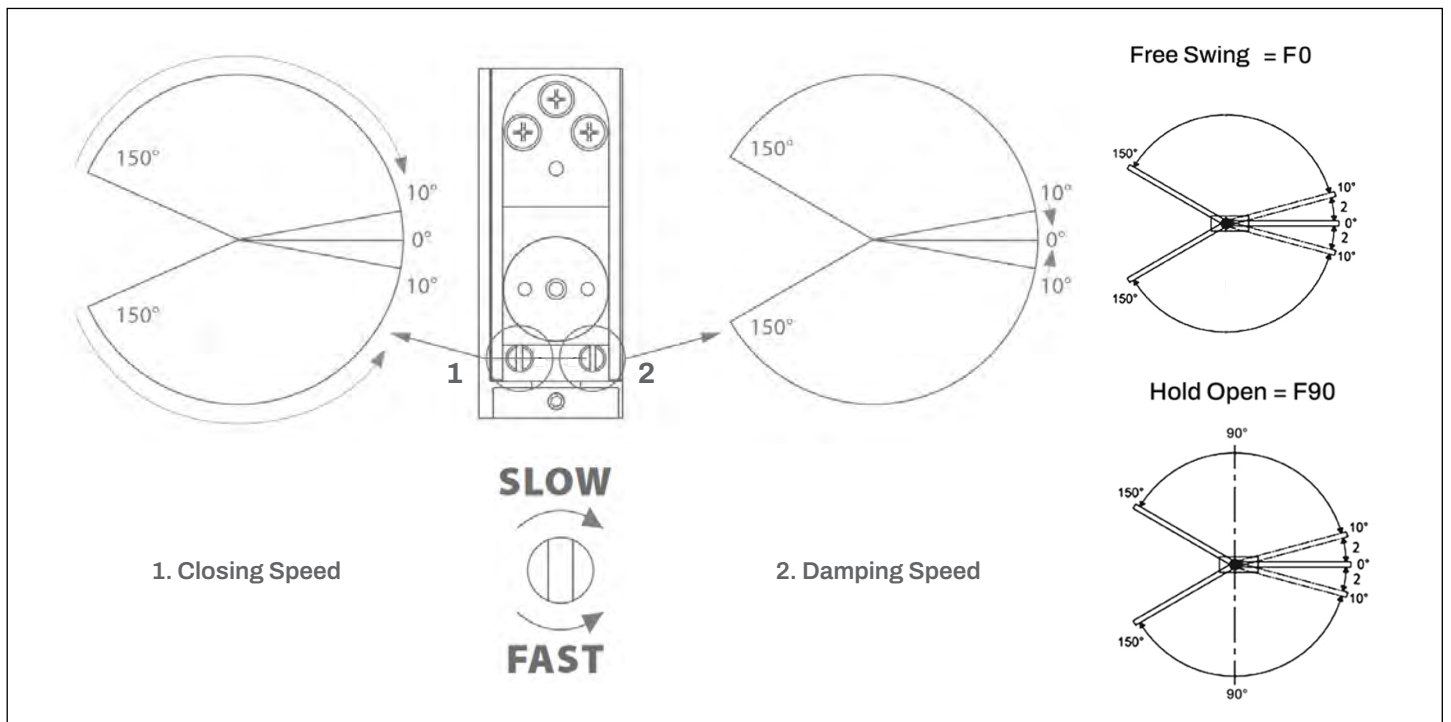

By changing the bracket, it allows you to increase the pivot point.

6 way adjustment on foot plate with Allen key

Corner Position

FM: Floor-Mounted



De-Central Position



Central Position



BI: Built-In



PIVOTICA PRO 150

Top Pivot Head - For Door Jamb

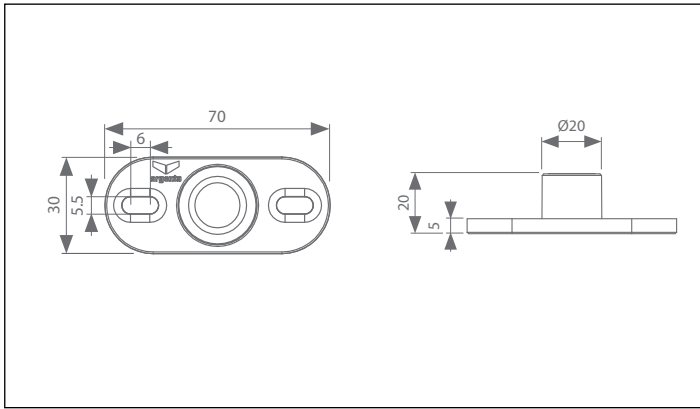

Top Pivot Head - For Door

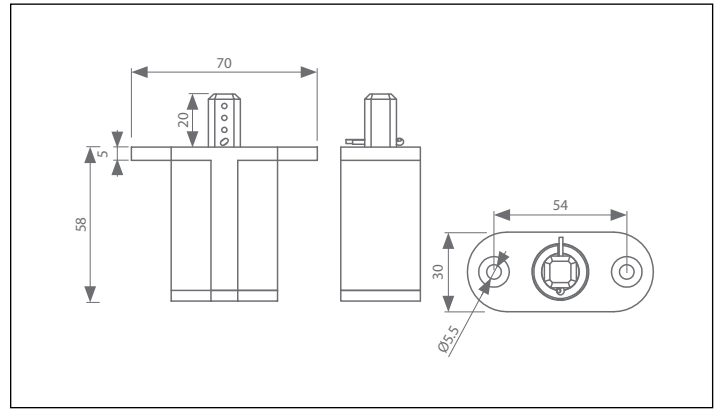

Pivot Body - Corner Position

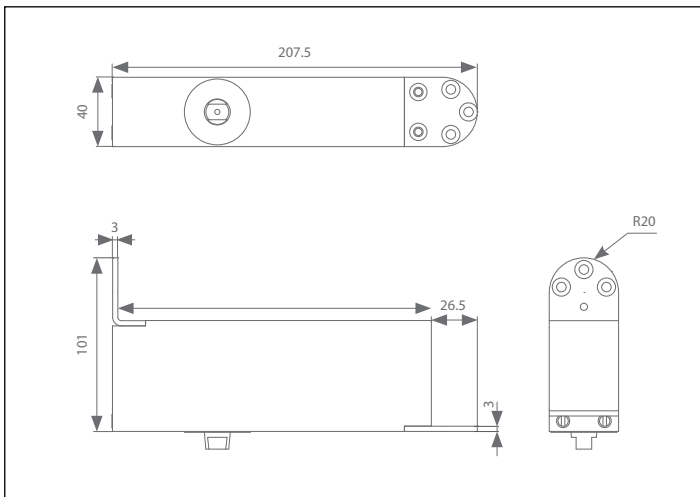

Pivot Body - Centre or Off-Centre

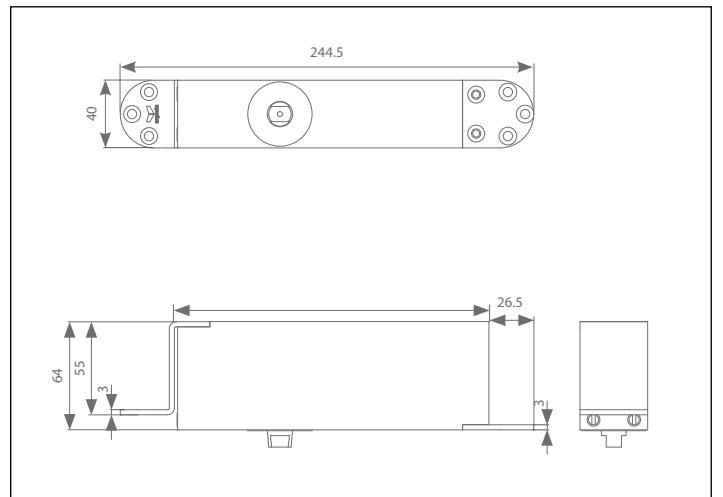

Floor Plate - Floor Mounted

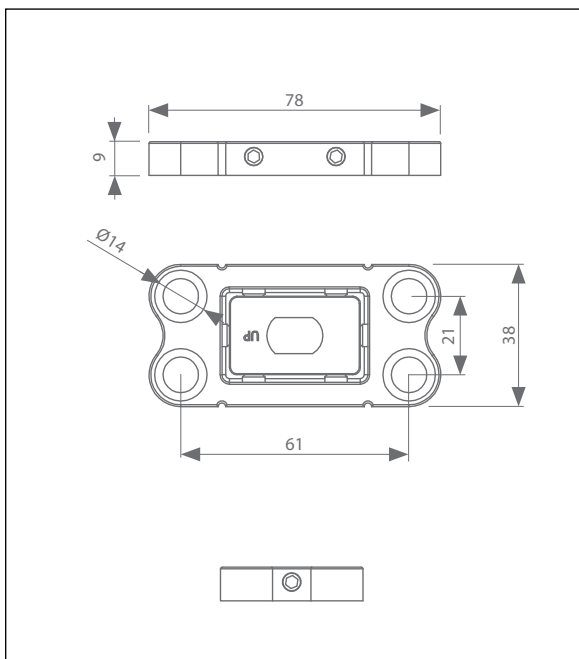

Floor Plate - Built-In

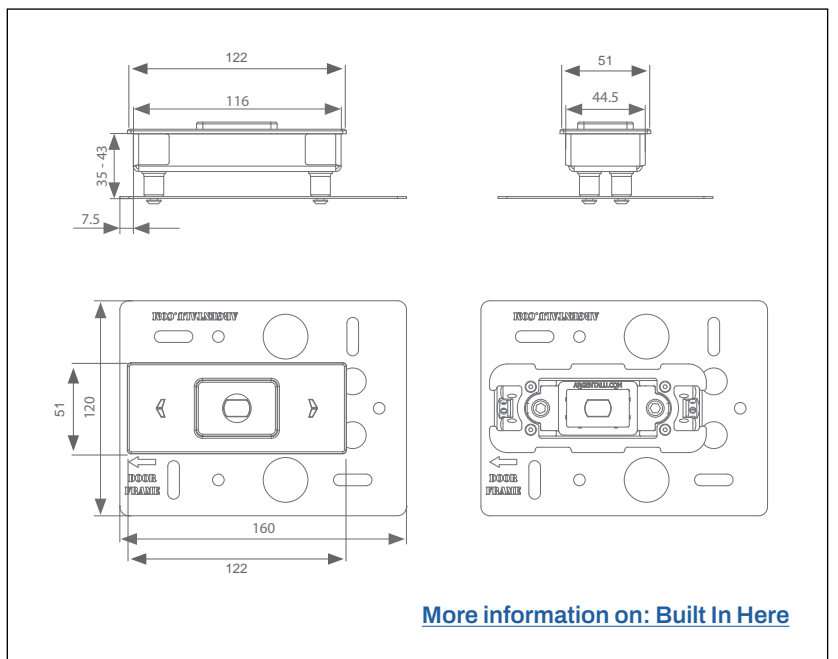

[More information on: Built In Here](#)

INSTALLATION OF PARTS FOR FLOOR MOUNTED

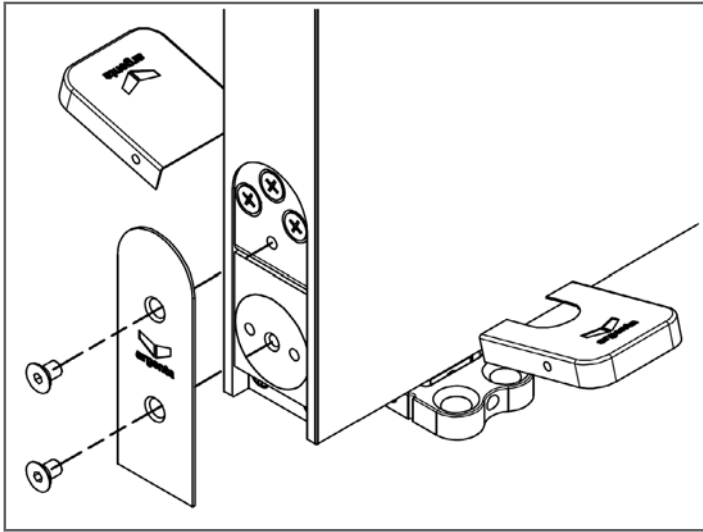

O - Pivot Body | N - Pivot Body Face Plate | J - Floor Plate | L/K - Floor Plate Cover Plate

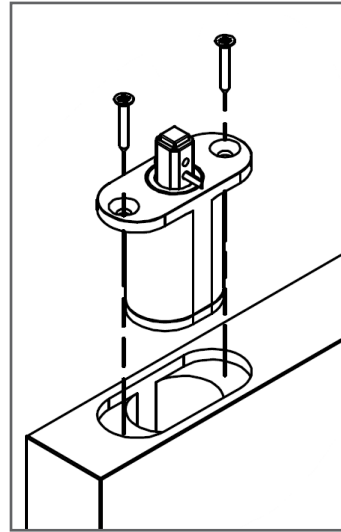

B - Top Pivot Head - For Door

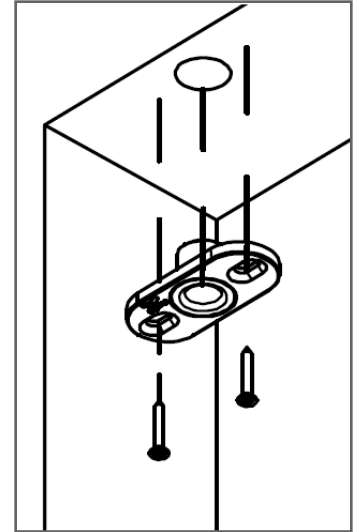

A - Ceiling Plate - For Door Jamb

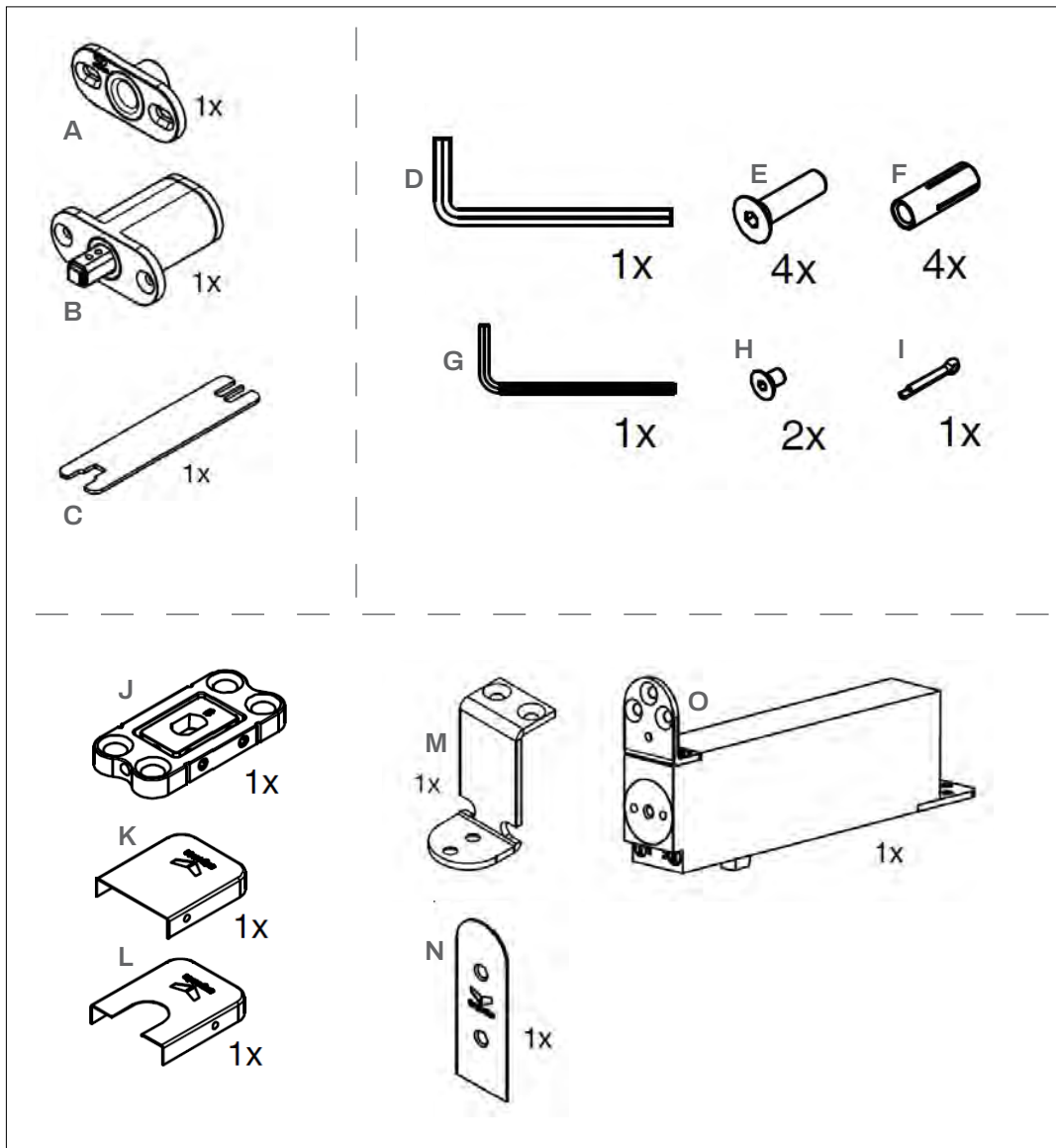

CONTENTS

- A. Ceiling Plate - For Door Jamb
- B. Top Pivot Head - For Door
- C. Adjustable Assembly Wrench
- D. Allen Key
- E. Fixing Screws
- F. Screw Casing
- G. Allen Key
- H. Fixing Screws
- I. Split Pin
- J. Floor Plate
- K. Floor Plate Cover
- L. Floor Plate Cover
- M. Bracket For Centre / Off-Centre Position
- N. Pivot Body Face Plate
- O. Pivot Body

INSTALLATION OF PARTS FOR BUILT-IN

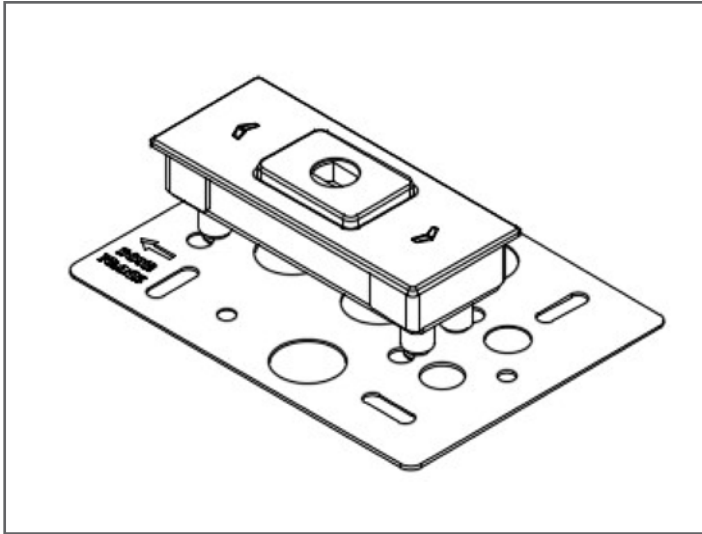

Built-In Plate

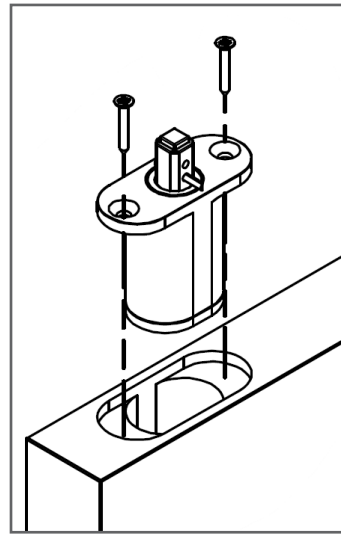

Top Pivot Head - For Door

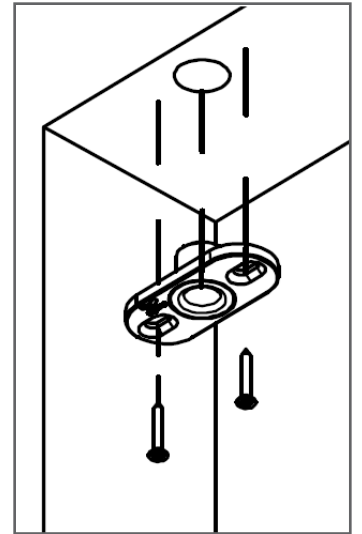

Ceiling Plate - For Door Jamb

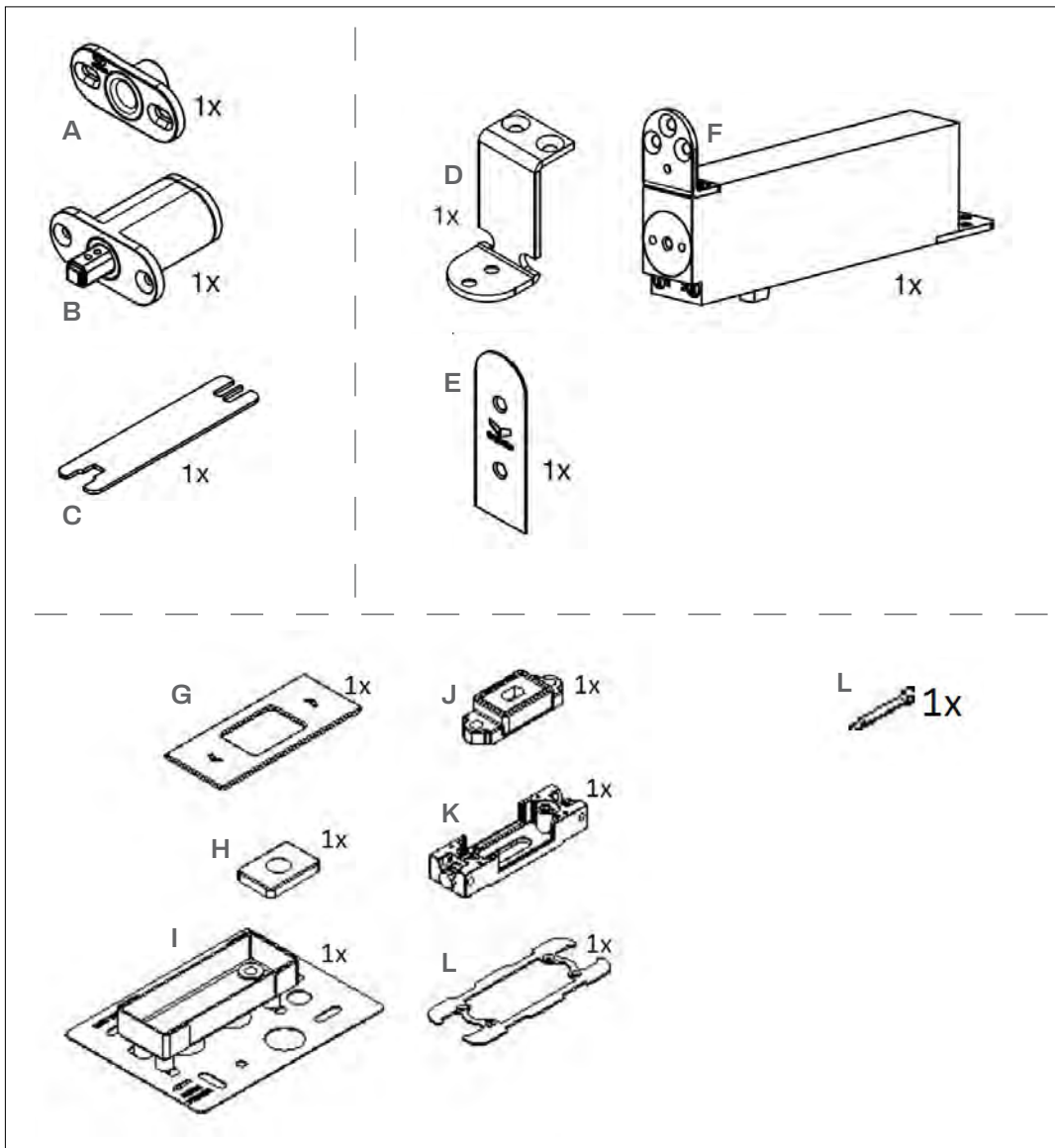

CONTENTS

- A. Ceiling Plate - For Door Jamb
- B. Top Pivot Head - For Door
- C. Adjustable Assembly Wrench
- D. Bracket For Centre / Off-Centre Position
- E. Pivot Body Face Plate
- F. Pivot Body
- G. main Cover Plate
- H. Internal Cover Plate
- I. Under-floor Mounting Unit
- J. Pivot Floor Plate
- K. Pivot Floor Plates
- L. Picot Floor Plates